

# [dual 1] series/parallel

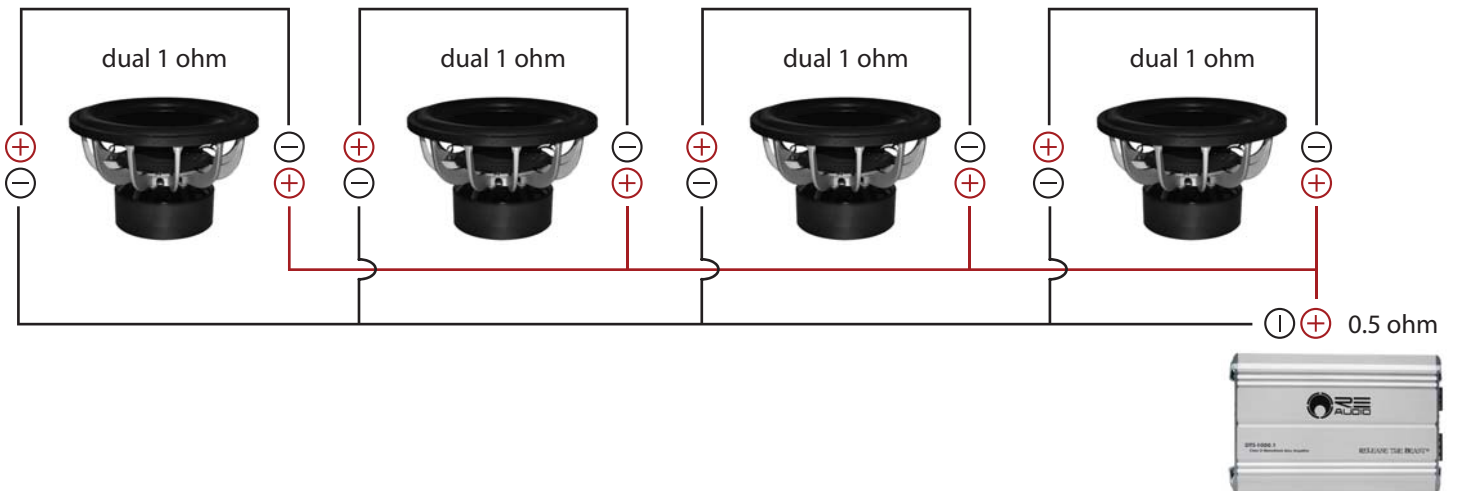

# [dual 1] series/series

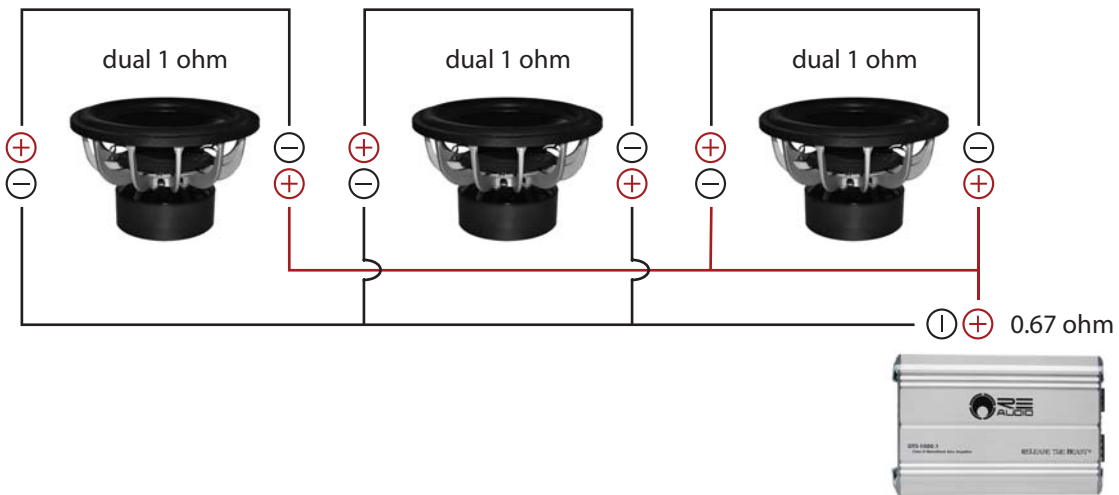
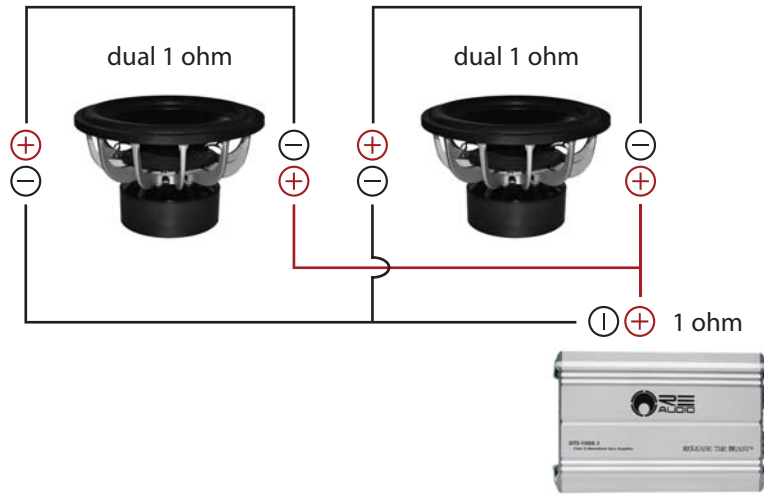
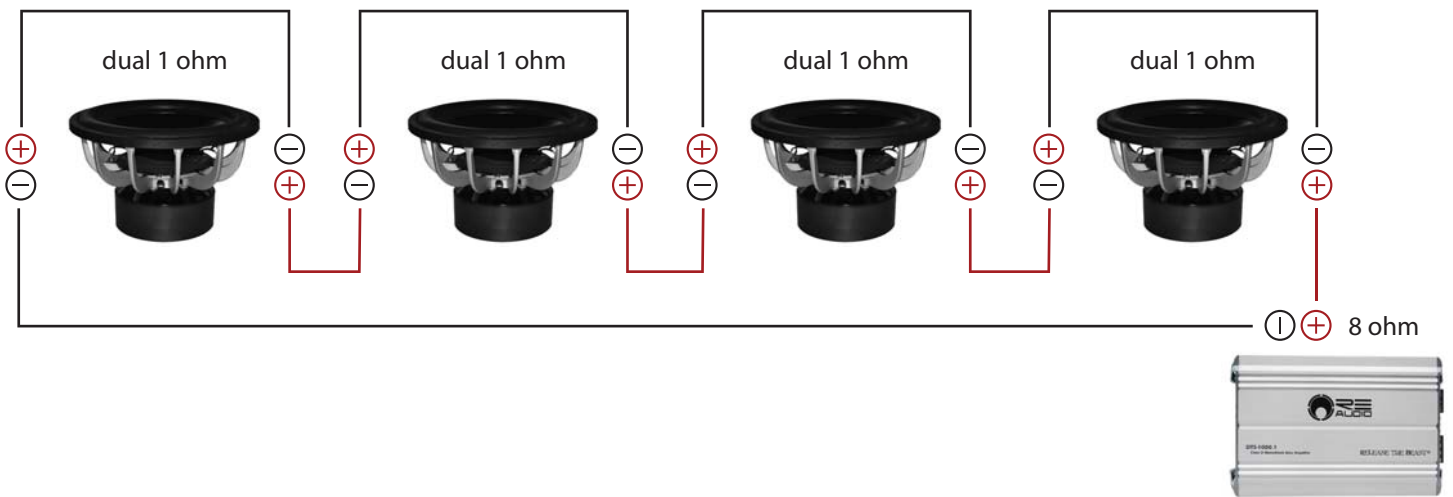
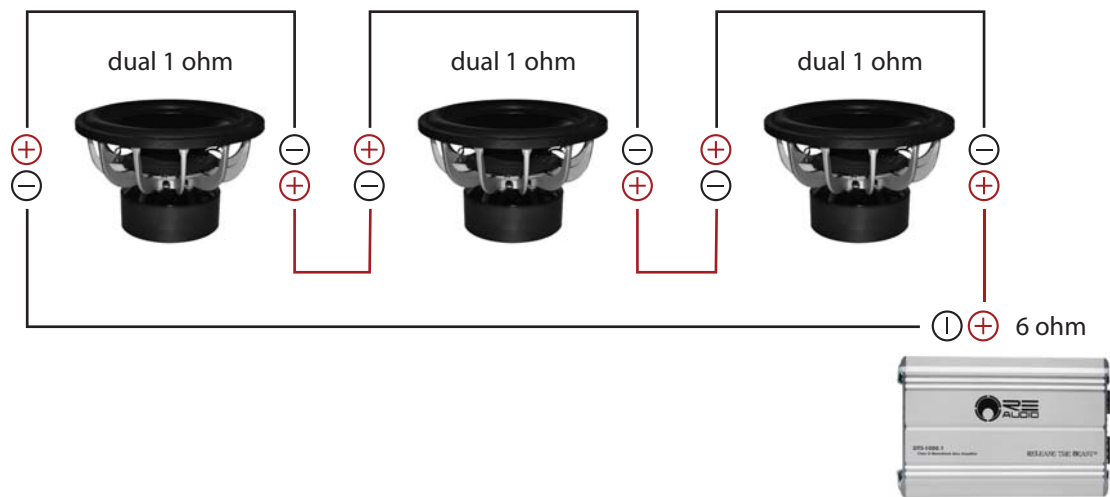
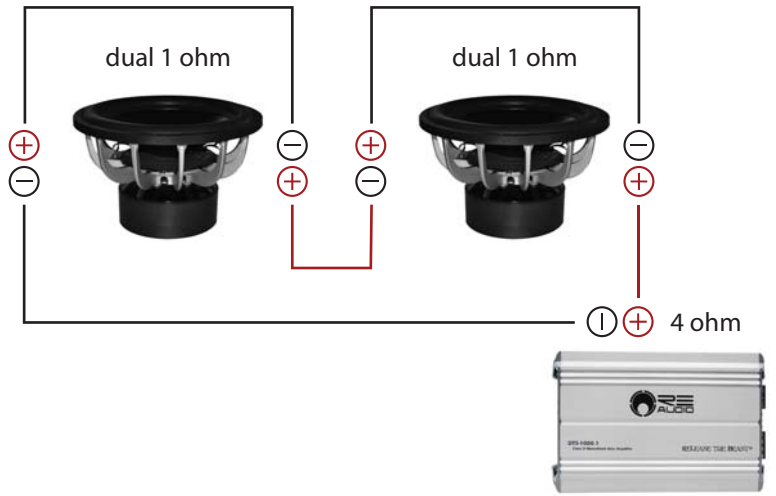

# [dual 2] parallel/parallel

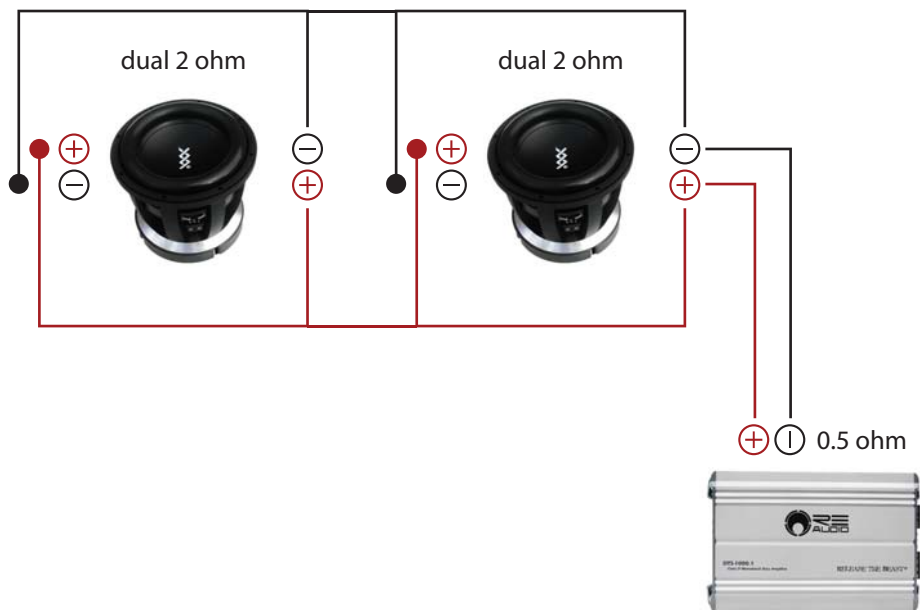
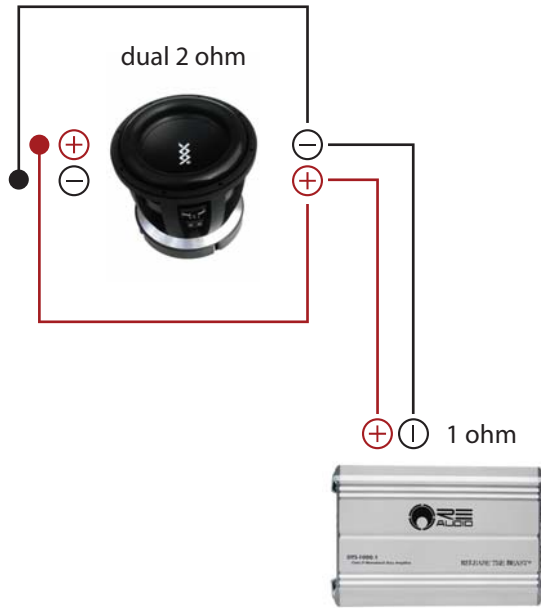

# [dual 2] series/parallel

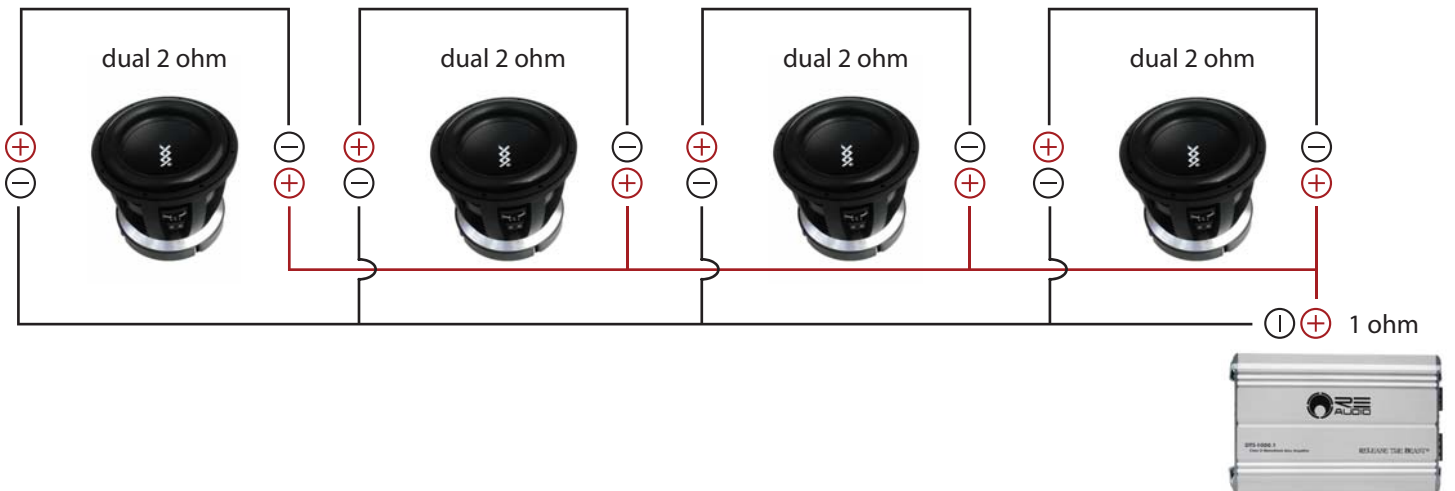
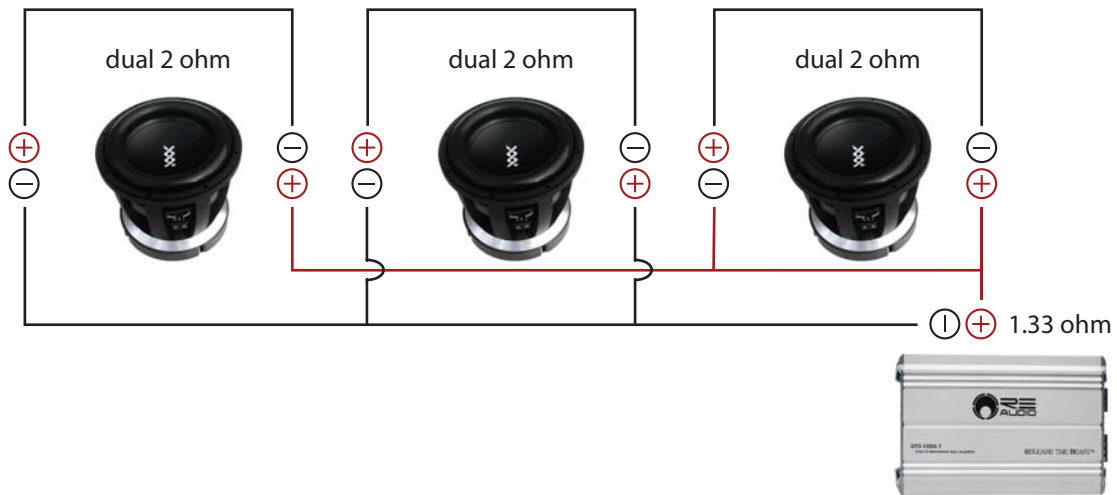
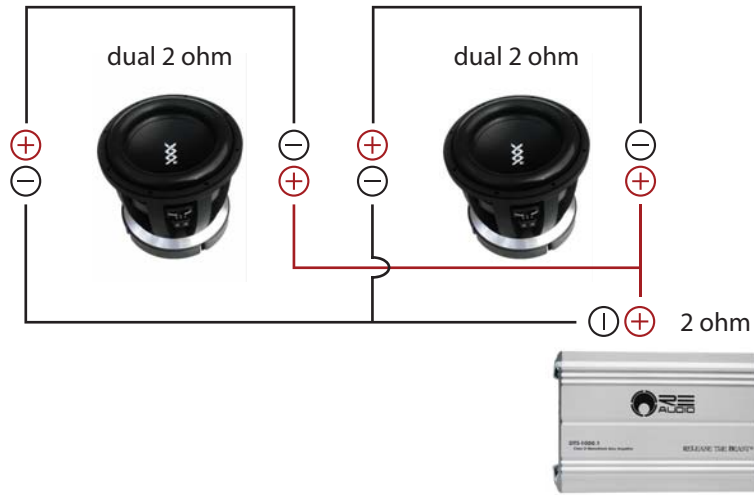

# [dual 2] series/series

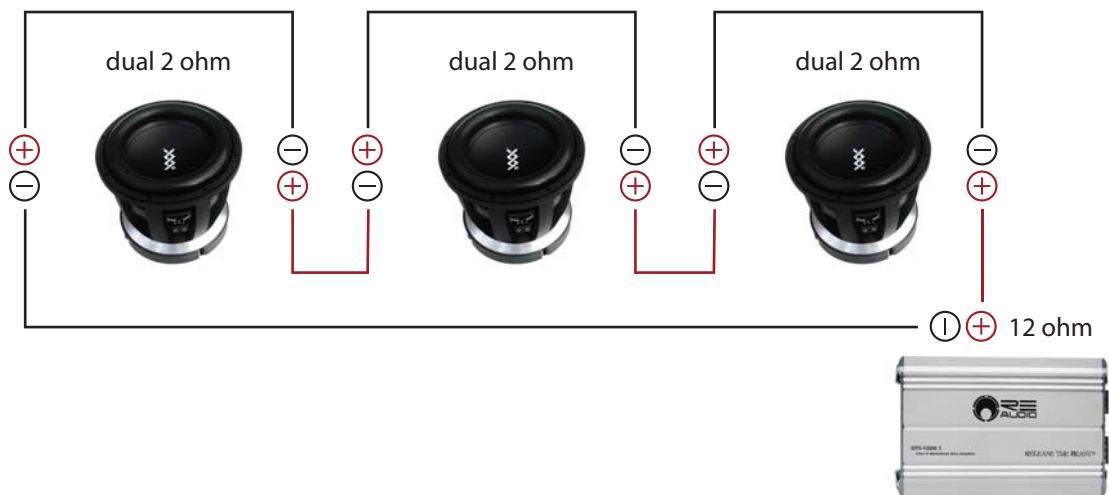
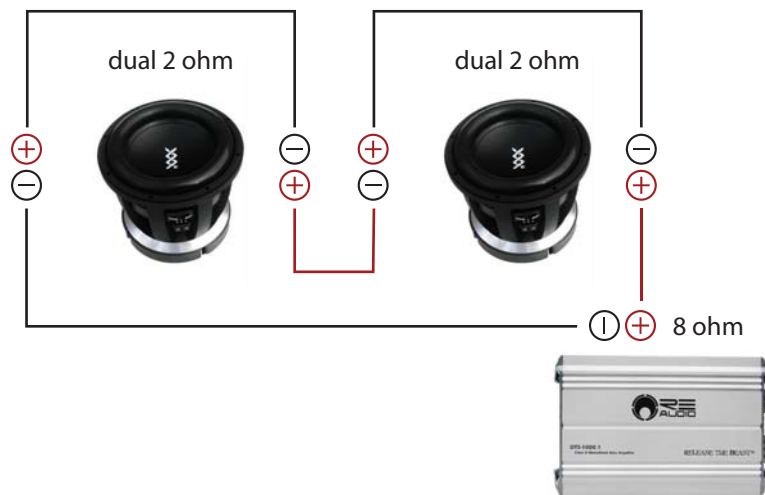

# [dual 4] parallel/parallel

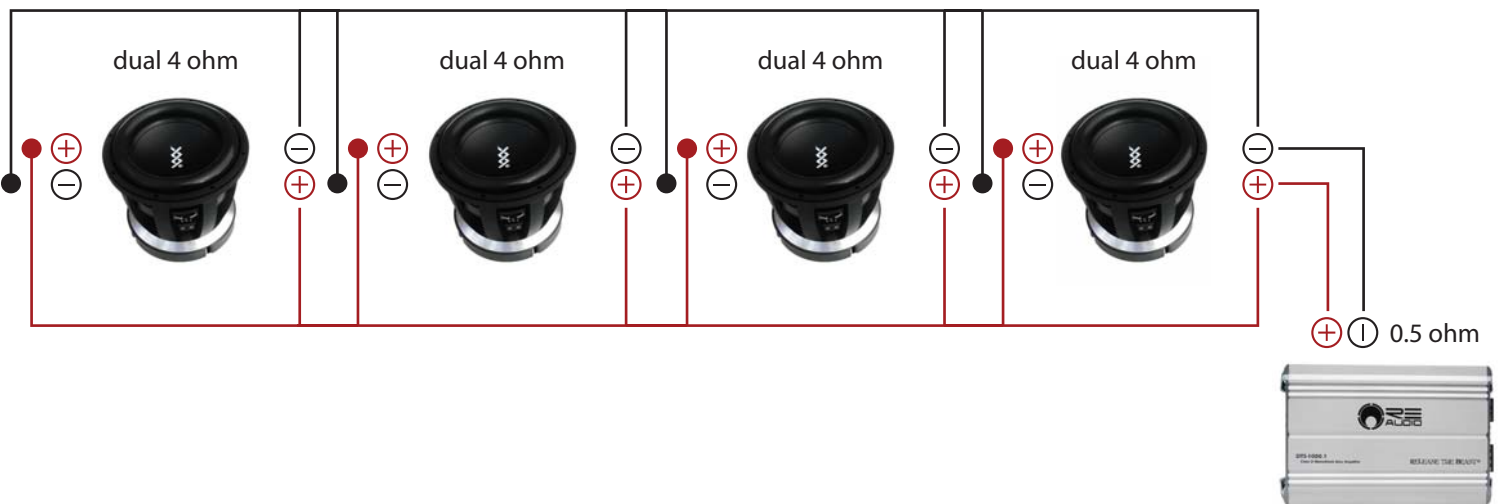
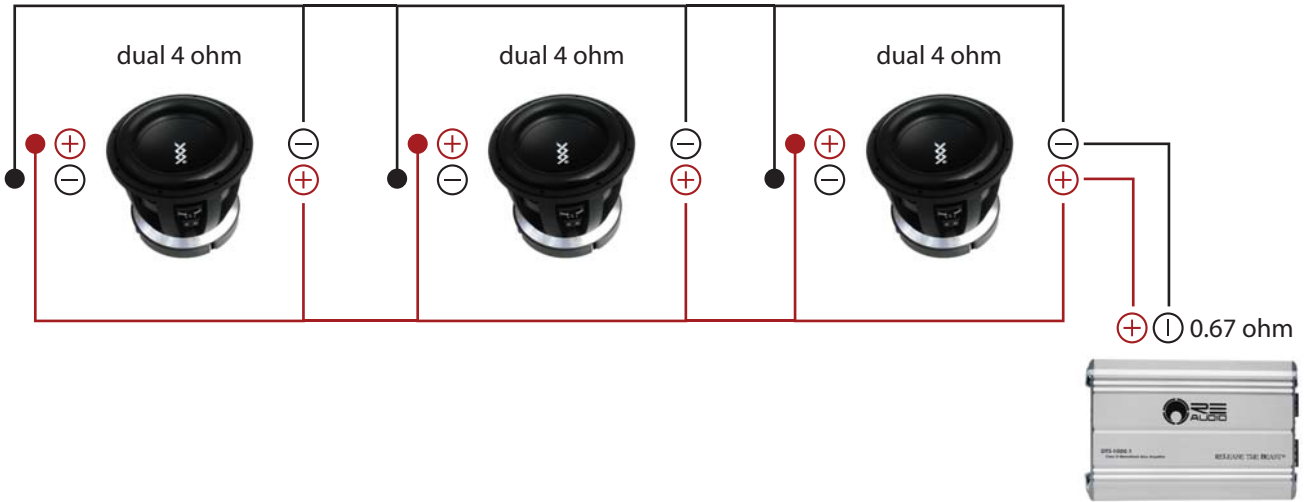
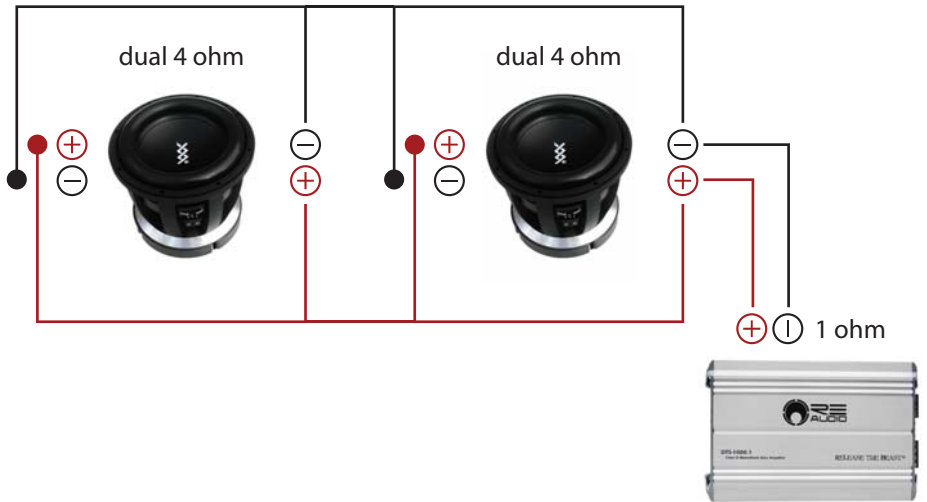
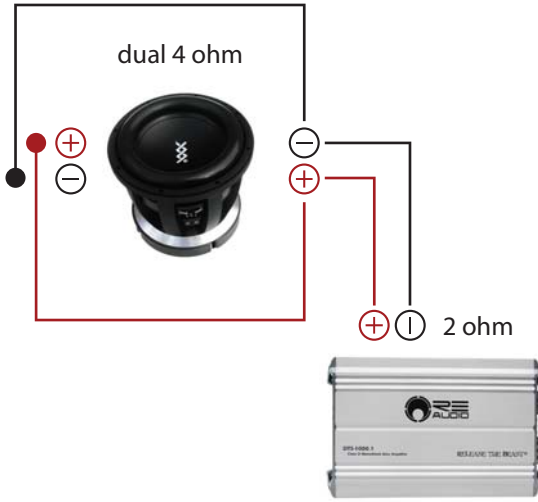

# [dual 4] series/parallel

